

FEA motor optimized
 25.5 mm voice coil
 Copper and aluminum voice coil
 Aluminum former
 Large neodymium magnet
 NPPV™ exponential cone
 CNC aluminum basket
 Rubber surround
 Conex™ progressive spider
 Computer optimized design
 Motor metal parts CNC machined

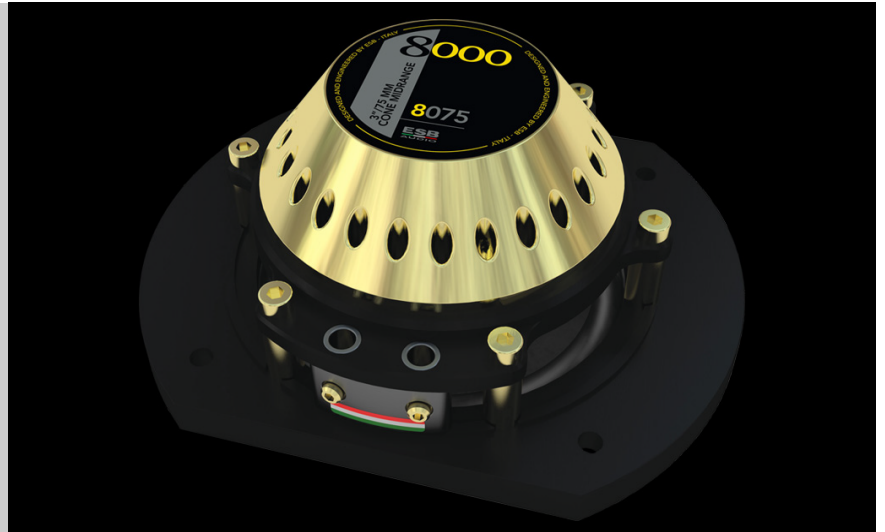

Neodymium magnet motor is optimized with FEA simulation to ensure perfectly symmetrical magnetic flux in both directions of the cone's run. Motor metal parts are CNC machined from solid and refined material for maximum magnetic flux linearity and minimum magnetic loss. This reduces distortion at high power levels.

25.5 mm CCAW (Copper Clad Aluminum Wire) double layer voice coil is wound on an aluminum former for exceptional power handling and compression-free reproduction, for even the most demanding musical passages.

Non pressed cellulose pulp exponential cone has a vinyl ester resin coating, ensuring a perfect balance between rigidity, weight, and self-damping. The cellulose pulp guarantees an extremely natural and linear reproduction in all musical passages, with an excellent extension at high frequencies without audible break-up. An aluminum dust cup fixed directly on voice coil former, increases and linearizes the extreme top of bandwidth.

The CNC aluminum basket ensures a drastic reduction of the cone's back reflections and a great torsional rigidity. High structural and torsional rigidity are a goal for perfect parts alignment, this requires very tight tolerances in the construction and assembling system. That brings better efficiency, more power handling and less distortion.

The exclusive rubber surround offers maximum linearity of travel and high reliability in extreme conditions. The axial ventilation system ensures high thermal dissipation capacity, power handling and reliability.

Large Conex™ spider allows a smooth and gentle run at low excursions, and gently holds the cone at high excursions, this increases the useful range of use.

Exclusive terminal connection design can accept very large cables.

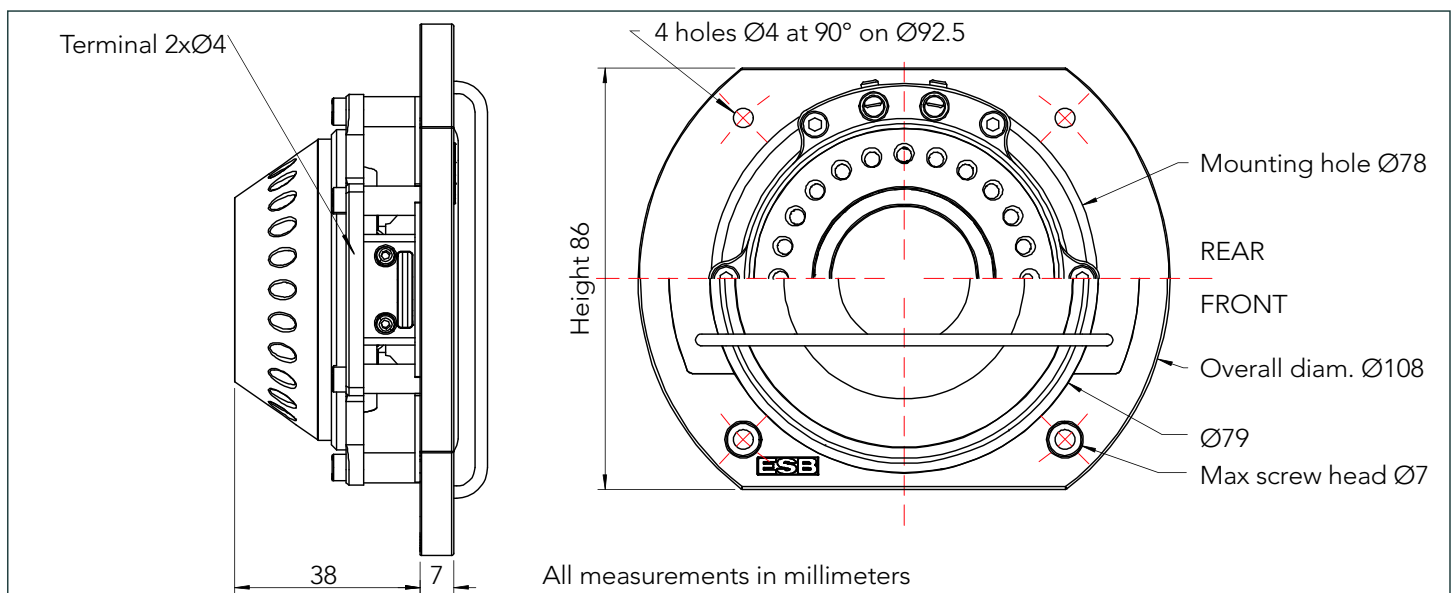

RESPONSE CURVE

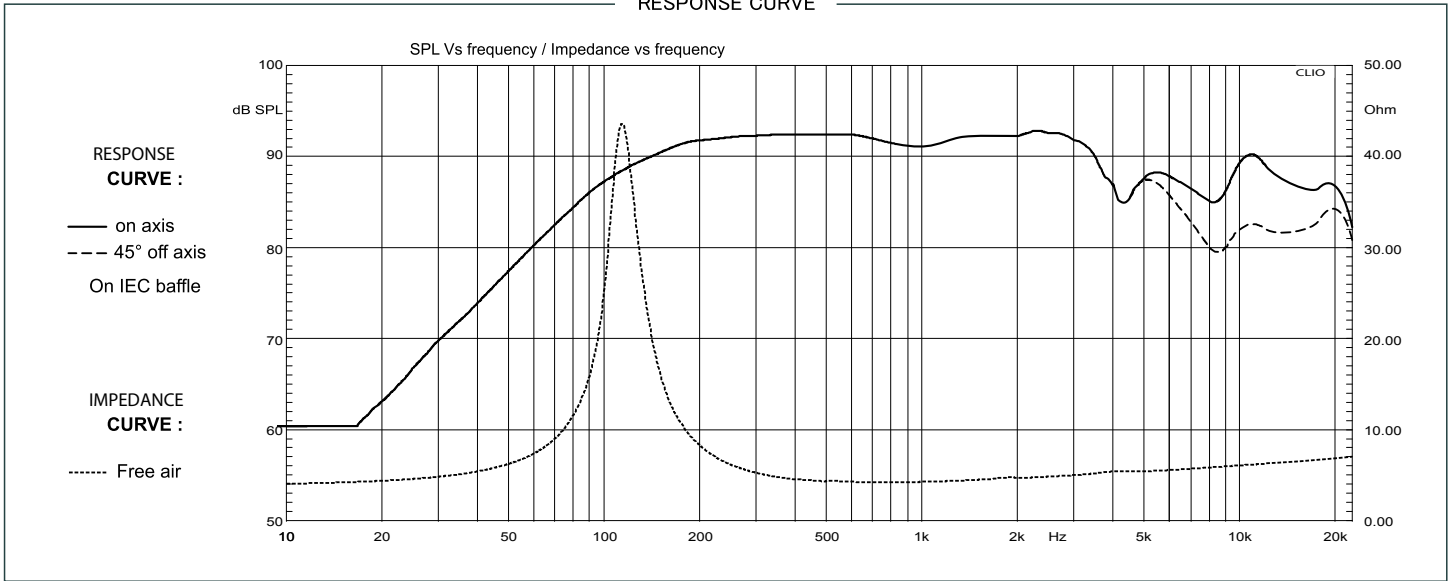

SPECIFICATIONS			
Technical Characteristics	Symbol	Value	Units
GENERAL DATA			
Overall Dimension	D x h	108 x 37	mm
Nominal Power Handling (AES)*	P	120	W
Transient Power *	Pp	240	W
Sensivity 1W/1m	SPL	91	dB SPL
Frequency Response		95 - 16.000	Hz
Cone Material		Not pressed pulp and vinylster resin	
Net Weight		377	g
*Nominal and Transient power @ High Pass 200Hz - 12db/Oct			
ELECTRICAL DATA			
Nominal Impedance	Z	4	Ω
DC Resistance	Ω	3.3	Ω
Voice coil Inductance	Lbm	0.34	μH
VOICE COIL AND MAGNET PARAMETERS			
Voice Coil Diameter	Dia	25.5	mm
Voice coil Height	h	5.7	mm
Magnetic Gap Height	HE	4.0	mm
Max Linear excursion	Xmax	±5.7	mm
Voice Coil Former		Aluminum	
Number of layers	n	2	
Magnet System		Neodymium YN52H grade	
Efficiency	η°	0.26	%
BL Product	BxL	3.83	Na
Magnet dimension	∅ x ∅ x h	45x29x5	mm
Magnet weight	m	37	g
T&S PARAMETERS			
Suspension Compliance	Cms	0.8	N/m
Mechanical Q Factor	Qms	4.76	
Electrical Q Factor	Qes	0.42	
Total Q Factor	Qts	0.39	
Mechanical Resistance	Rms	0.36	Ω
Moving Mass	mms	2.45	g
Eq. Comp. Air Load	VAS	0.95	l
Resonance Frequency	Fs	113	Hz
Effective Piston Area	SD	29	cm ²

CROSSOVER VALUE		
Fc	Crossover frequency	Hz
L	Inductor	mH
C	Capacitor	μF
R	Resistance	Ω
S	Crossover Slope	dB/Oct

SEALED AND PORTED SUGGESTED VOLUME

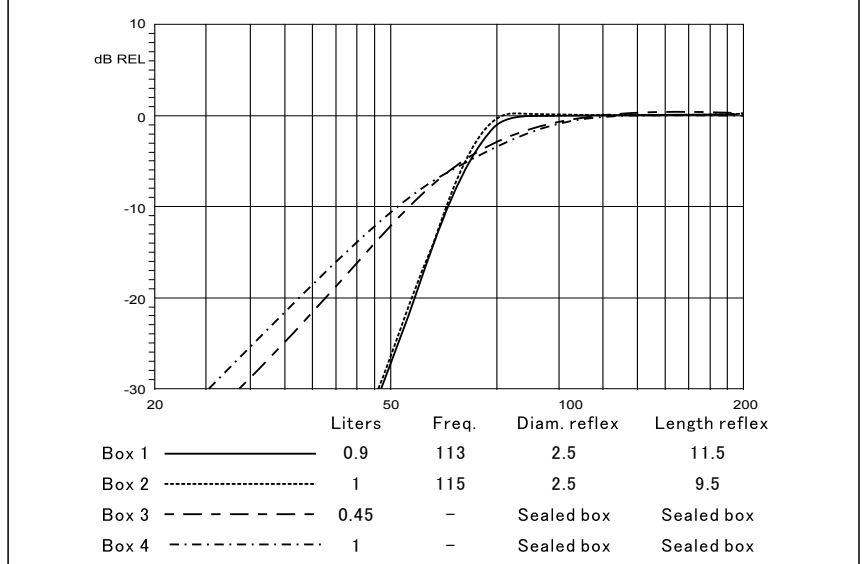

SUGGESTED APPLICATION

